



Changes for the Better

MITSUBISHI CNC
M700V Series



The Best Partner for Your Success

for a greener tomorrow



Mitsubishi CNC M700V Series

The best machines for top level manufacturing

The one and only. Only top level manufacturing can survive.

Mitsubishi CNC M700V Series is a state-of-the-art model that provides high-speed and high-accuracy machining and advanced control technologies. These Functions are for customers who keep challenging for more production output, with a worldwide recognized machine for today's globalized industry.

M700VS Series is an integrated control unit and display type.

M700VW Series also comes with Windows®XPe.

These two types of Mitsubishi CNC M700V Series support top level manufacturing.

Windows® is a trademark or registered trademark of Microsoft Corporation in the United States and other countries.

The Best Partner for Your Success

MITSUBISHI CNC

M700V series



[Complete NANO]
Controls everything from the CNC's operation to servo processing with a least command increment of 1nm



[5-axis, multi-axis]
Controlling multiple axes allows the positioning of the tool center point



[High-speed, high-accuracy]
High-quality machining by determining appropriate shapes and avoiding unnecessary deceleration



[Easy operation]
Simple programming system for machining center and lathe



[High-speed, high-accuracy]
High-speed and high-accuracy control of the drive system is achieved by estimating program paths from beginning to end



[Customize]
Tools used in developing solutions for control customization

M700VS and M700VW Series, advanced Mitsubishi CNCs for next-generation machining

Lineup

[System Configurations & Product Lines]

M700V series



Mitsubishi CNC
M700VW Series
M700VS Series

M700VW Series

M700VS Series

Drive Unit



Multi-hybrid drive unit
| MDS-DM Series



High-performance drive unit
| MDS-D/DH Series



Ultra-compact drive unit with
built-in power supply
| MDS-D-SVJ3/SPJ3 Series

Servo Motor



Medium-inertia motor
| HF Series



Low-inertia motor
| HF-KP Series

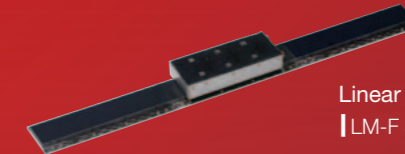

Linear servo motor
| LM-F Series

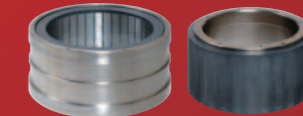

Direct drive servo motor
| TM-RB Series

MELSOFT (Tools)



Personal computer+Windows®



NC Designer
NC Monitor
NC Explorer
NC Trainer
MS Configurator
NC Configurator2
GX Developer
etc.

Windows® is a trademark or registered trademark of Microsoft Corporation in the United States and other countries.

Machine Operation Panel



Spindle Motor



High-performance
spindle motor
| SJ-D Series
| SJ-V Series



Low-inertia and high-speed
spindle motor
| SJ-VL Series
| SJ-VLS Series



Tool spindle motor
| HF-KP Series
| HF-SP Series



Built-in spindle motor

From drive units to servo/spindle motors —————
Advanced CNC components for higher performance

Technologies

Basic Performance and Functions

For higher speed and higher accuracy
Bringing the complete nano world closer to you

Mitsubishi Electric Factory Automation technologies are condensed into a 64 bit RISC processor and an exclusively developed high speed LSI. The basic CNC functions, built-in PLC and graphic performance are all improved. The M700VS has been downsized with power consumption reduced by 66% compared to our conventional Windows-based control models while maintaining the same performance. Windows®XPe-based M700VW was designed with expandability and stability to enable a higher level of custom functions.

Machining Program Processing Speed



(Note 1) BPM is the number of machining program blocks processed per minute.
(Note 2) M700VS's machining program processing speed is 67.5kBPM.

User Macro Processing Performance



Built-in PLC Basic Instruction Processing Performance



Windows® is a trademark or registered trademark of Microsoft Corporation in the United States and other countries.

M700V series

Complete Nano Control



All operations from program values to servo commands are done in nanometer units. Interpolation is at the nano-unit level even when program commands are in micrometer units.

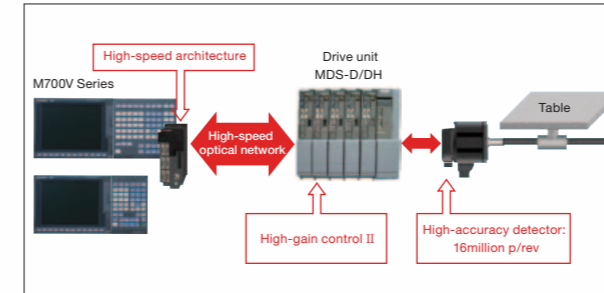

Speed command fluctuation reduced

In complete nano control, the position command calculation fraction of the interpolation calculation is small, so fluctuations in speed command due to the fractions is reduced. This reduces acceleration fluctuations, resulting in finer lines at the time of repeated acceleration/deceleration.

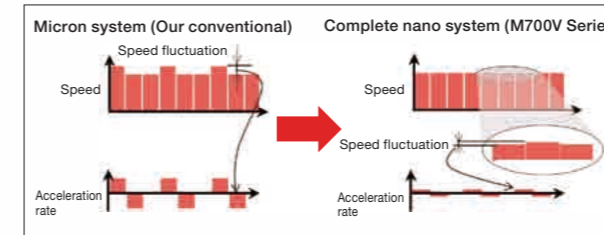

Interpolation calculation accuracy improved

Even with one-micron-unit commands in the machining program, interpolation is in nanometer units. As the calculation accuracy of a block intersection is improved, lines on the surface is finer.

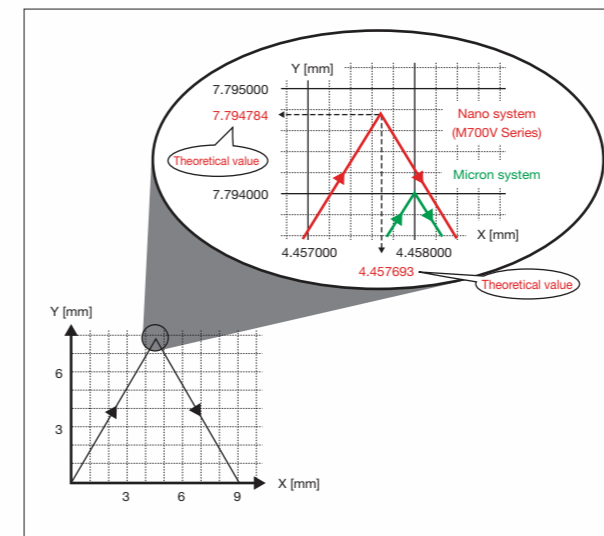

PLC Axis

Indexing function

By setting the number of stations required for the application, the drive automatically sets up equal intervals between each station. Positioning of the axis is only possible by commanding the station number.

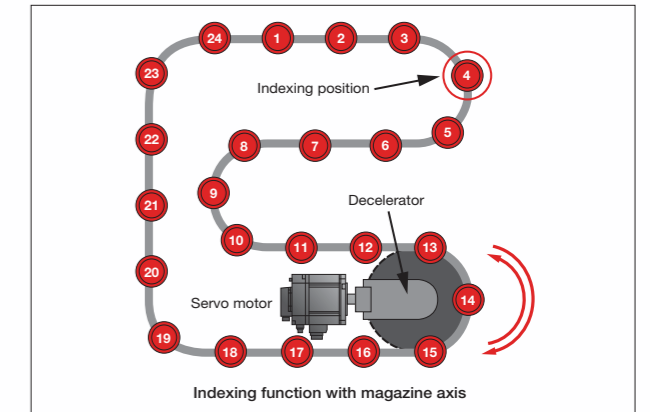

PLC axis mixed control

Even if a pallet is changed, the axis can always be controlled as an NC axis in the machining area, and as a PLC axis in the setup area, which enables setup of a rotary axis without stopping machining.

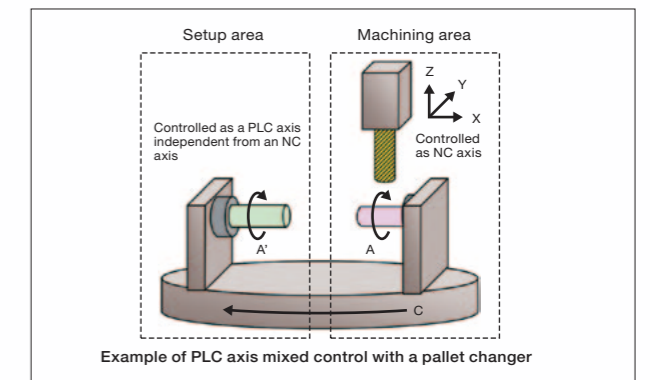

Index Modification Function of PLC Instructions

- The index modification function is available, which is one of MELSEC's wide variety of instructions.
- Repetitive programs can be written easily.

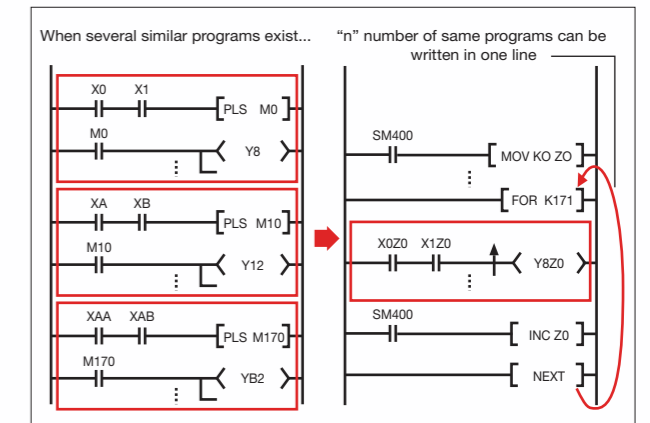

Technologies

Supporting Machine Tool Accuracy Improvement

Calculated control (OMR control) of the drive system based on the machine model realizes optimum machine operation

OMR-DD Control (High-speed synchronous tapping)

Optimum Machine Response Direct Drive



A high-speed error-compensation function is used for controlling the spindle and servo, enabling accurate tapping.

(Note) This function is available with MDS-D/DH and MDS-DM (one axis only).

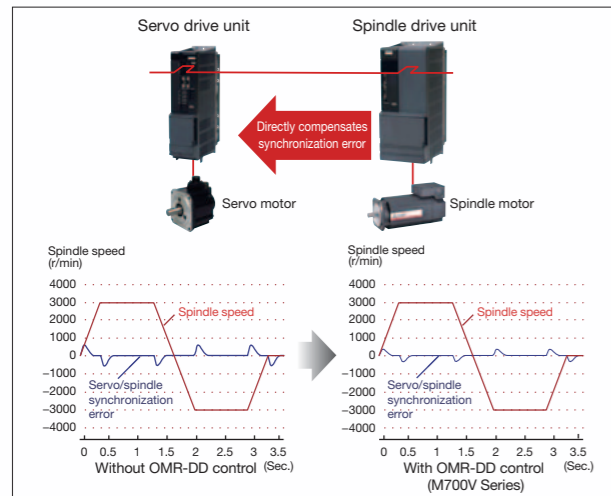

Machine-end Compensation Control

Corresponds to machine resonance fluctuations

By compensating for the deflection between the motor-end and machine-end, the part shape at a high speed and acceleration rate can be compensated for. The optimal shape can be obtained at a low feed rate and also compensate for the outward expansion of the shape at high feed rates.

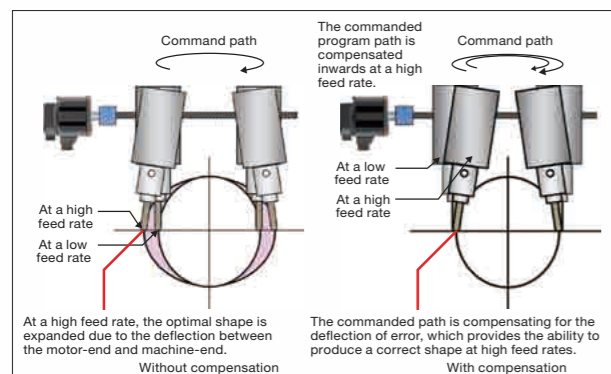

Adaptive Notch Filter

This function is used to estimate the resonance frequency of the machine and automatically adjust notch filter parameters. This enables the system to monitor the machine fluctuations and prevents repeated fluctuations caused by aged deterioration.

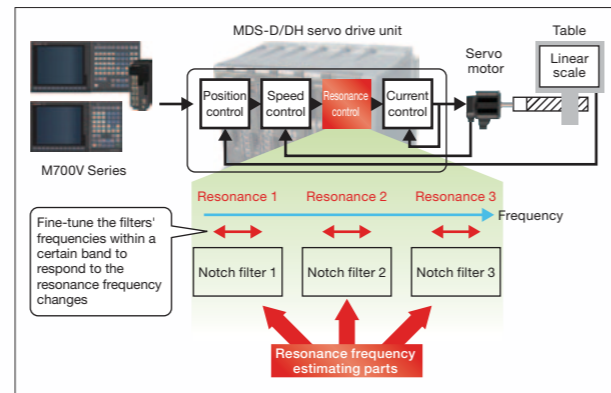

Lost Motion Compensation Control Type 3

This control can compensate for not only the machine friction but also the spring and viscosity elements. Thus quadrant protrusions, which are generated in circular cutting, can be compensated for within a wide range from low-speed to high-speed cutting.

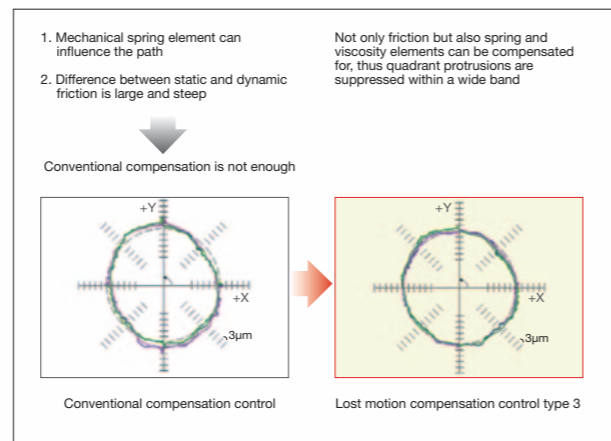

Position-dependent Gradually Increasing-type Backlash Compensation

Protrusion is reduced by gradually changing the backlash compensation amount according to the reversal of axis travel direction, which enables higher-accuracy machining.

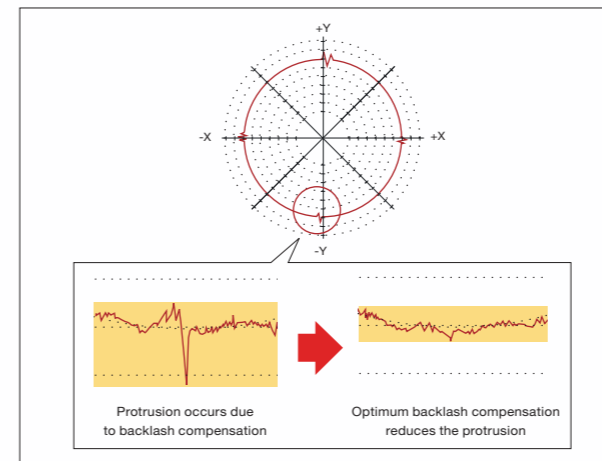

Position Loop of Spindle Control

High traceability to command (High-gain control II), which has been developed in servo axis control, is now available on spindles, contributes to shorter machining time and higher accuracy.

Spindle/C-axis control

The spindle's constant position loop control has eliminated the zero point return time when switching from the spindle to C-axis.

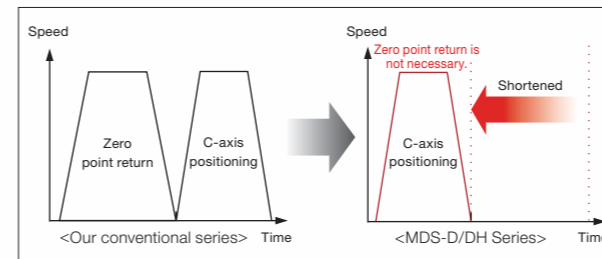

Orientation time is reduced

Deceleration is performed with the maximum torque to minimize the spindle orientation time.

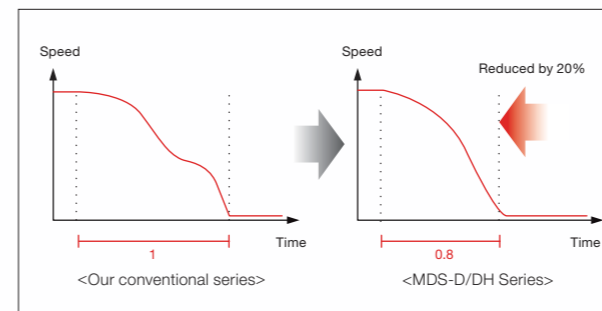

Heavy cutting performance improved

Heavy cutting performance has been improved with the addition of position loop control on the spindle. By lowering the impact load fluctuation, the speed fluctuation rate has been reduced to less than 1/2 of our conventional system.

M700v series

Two-way Pitch Error Compensation

The pitch error compensation function has been improved. By setting the compensation amounts separately for the positive and negative directions, different compensation can be applied to each direction.

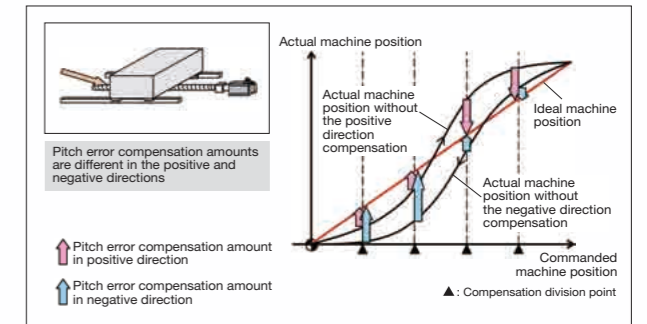

Lowering Heat Generation of Spindle Motors

Reduced harmonic current mitigates heat generation in the spindle motor.

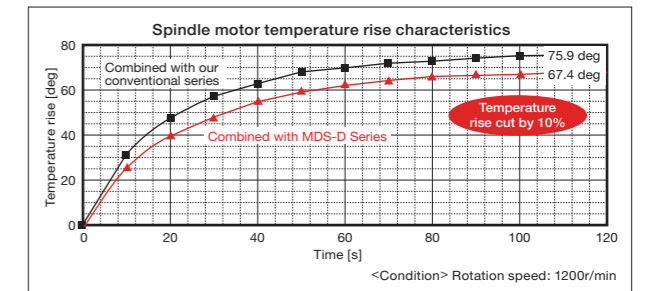

Automatic Temperature Compensation of Spindle Motor

A built-in thermistor detects the spindle motor's temperature to compensate for the acceleration/deceleration time when the motor is at a low temperature. It is also possible to monitor the spindle motor's temperature on the NC screen.

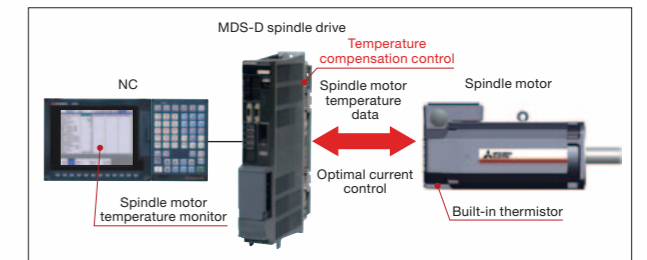

Spindle acceleration/deceleration time shortened

The change of accel/decel characteristics due to motor temperature changes can be suppressed, which allows the system to be controlled at a constant accel/decel rate.

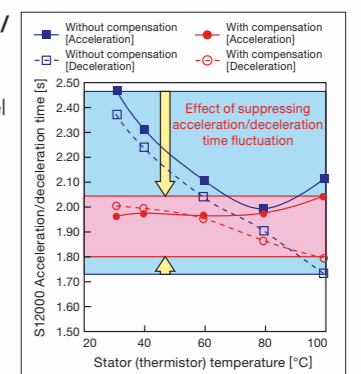

Technologies

Human Machine Interface provides for better visibility and operator ease of use

Easy-to-use interface with useful functions



HMI for Easier and More Visible Use

(HMI: Human Machine Interface)

Screen structure linking to the operation processes

Operation processes are divided into three steps, "Monitor", "Setup" and "Edit", and necessary information is aggregated into three screens. These screens can be displayed by touching a single button on the keyboard.

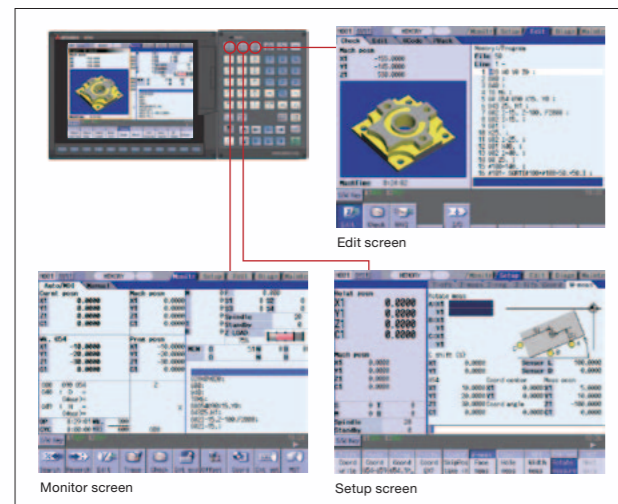

2-part system display

The Monitor screen of the 2nd part system can be displayed together with the 1st part system. Switching screens is not necessary.

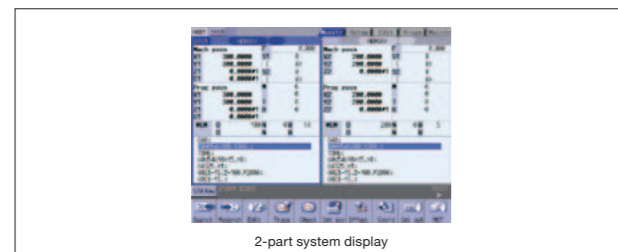

Pop-up screens

Tabs allow the user to select necessary operations from the operation menu, and pop-up screens allow the user to access desired information while the original screen remains displayed. For displays with a touch panel, a keyboard can be displayed on the screen.

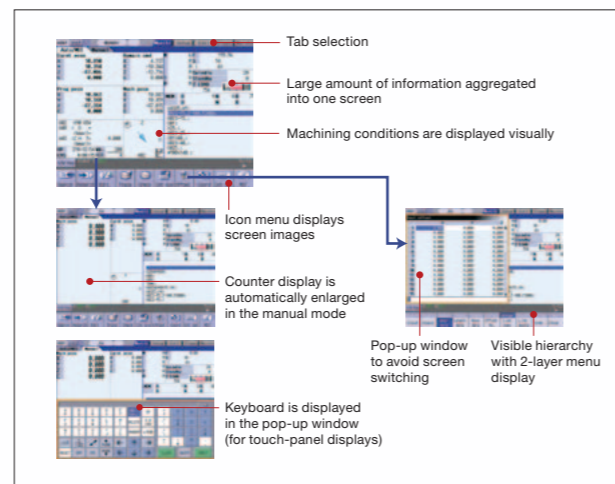

Menu customization function

Menu keys on the bottom of the screen can be freely arranged. Frequently used menu keys can be put together on the first page.

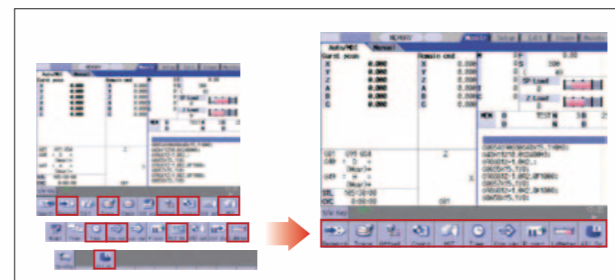

M700V series

Operation Support

Manual/Automatic backup function

- Batch-backup of the NC data into the memory card/USB memory inserted in the front interface of the display is possible. For the built-in hard disk type M700VW Series, backup in the hard disk is also possible.
- Data is automatically backed-up at a certain interval set by the parameter.

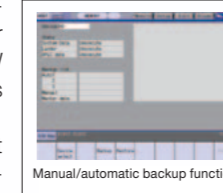

Operability of operation search improved

Using the program edit screen, it is possible to execute a program from the line specified by the cursor. The operation search immediately detects the edited part to check the content of operation.

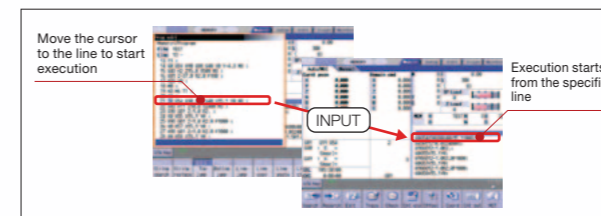

Guidance function

By pressing the help button, guidance (operation procedure /parameter descriptions/alarm descriptions/G code format) regarding the currently displayed screen will be shown.



NAVI MILL (for machining center)/ NAVI LATHE (for lathe)



Simple programming function

- Programs are automatically created for each process when an operator selects machining process and inputs data on screen. A tool path can be graphically drawn for the program check.
- This function also supports in-tilted surface machining.

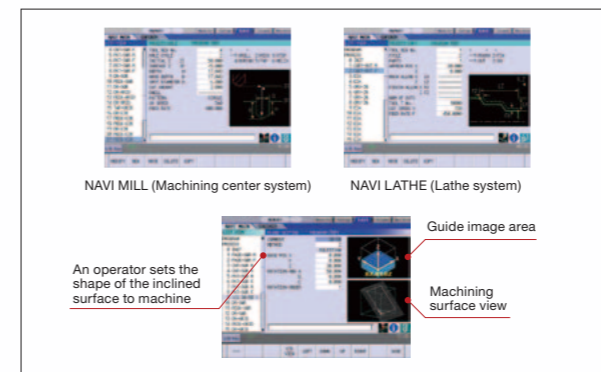

Program input error warning function

- The added 3D solid model check function allows more realistic cutting check.*
- This function helps an operator to input and check programs. Errors are indicated when a decimal point is omitted.

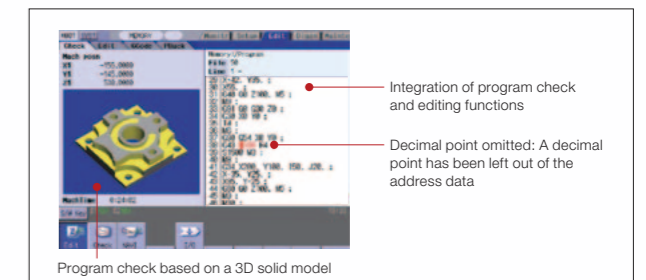

*Available with M700V Series (M System) only.

Operability of program restart function improved

Even if a machining program is stopped for reasons such as tool breakage, the program can be restarted when it has been stopped using only the INPUT operation.

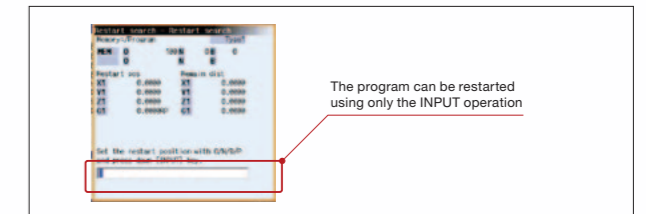

Menu list

Menu list buttons are newly introduced. With these buttons, the screen desired for display can be called up directly. The selected screen's function outline is also displayed.

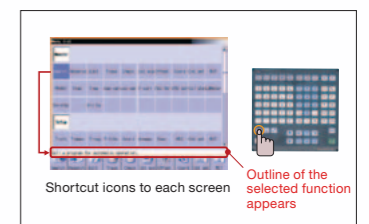

Program Operation

- Machining programs in the memory card or in the hard disk (for M700VW Series) can be directly searched and run. Direct edit is also available.
- Sub-program call is available from machining programs stored in the memory card or hard disk.
- The program format is unlimited.

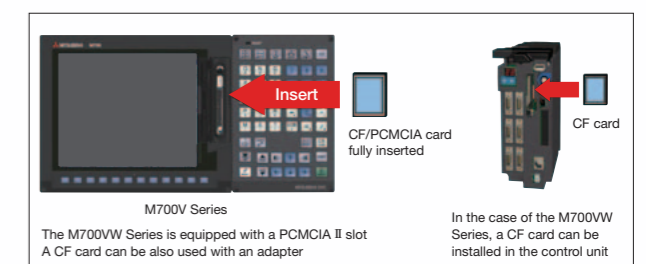

Technologies

For High Quality machining with smoother finish and faster performance

Five-Axis Machining functions such as Tool Center Point and SSS control have been enhanced.

With the enhancement of these functions, five-axis control will provide high-end performance.

The advanced five-axis control provides great potentialities.

SSS Control (Machining Center System) *1st part system only

Super Smooth Surface



- By judging part program paths, unnecessary deceleration is reduced, even when fine steps in the program exist. This provides a smooth finish without deviation for die-mold machining.
- Machining time can be shorter by 5 to 30% relative to our conventional system, especially more effective at a higher feed rate.
- SSS control ensures high machining stability and quality with virtually no effects resulting from cutting shape or speed.
- Optimum speed control is always performed even with a program with an error, resulting smooth surface in short time.

- SSS control is now available for the most basic function of five-axis simultaneous interpolation control, tool center point control. It compensates uneven paths output from CAM to smoothly joint the tool center points' path.
- By realizing speed control not susceptible to tool center point path error and fluctuation of rotary axis travel amount, high-grade cutting in five-axis simultaneous machining using tool center point machining is achieved.
- This function suppresses the vibrations of the tool by moving the rotary axis smoothly. Even when this function is active, the Tool Center Point path moves according to the command program path.

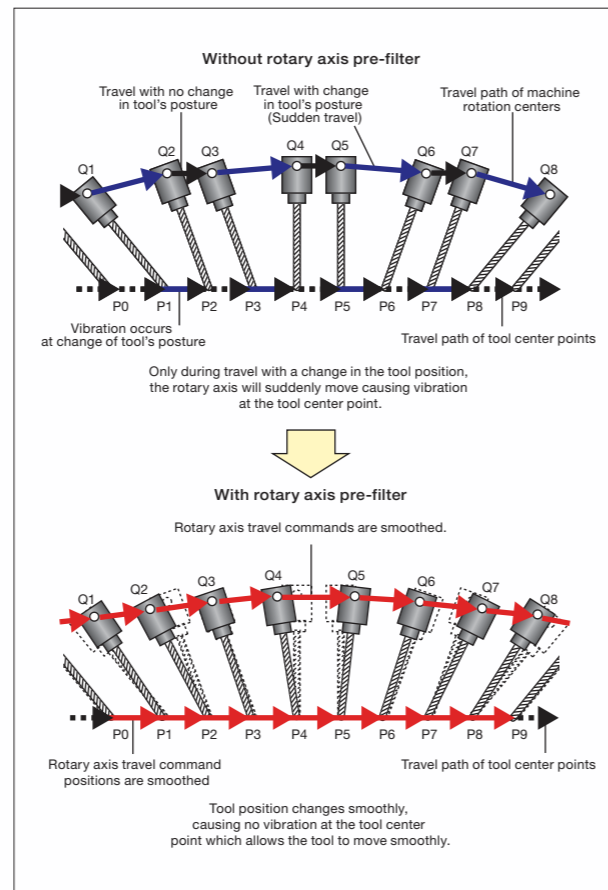
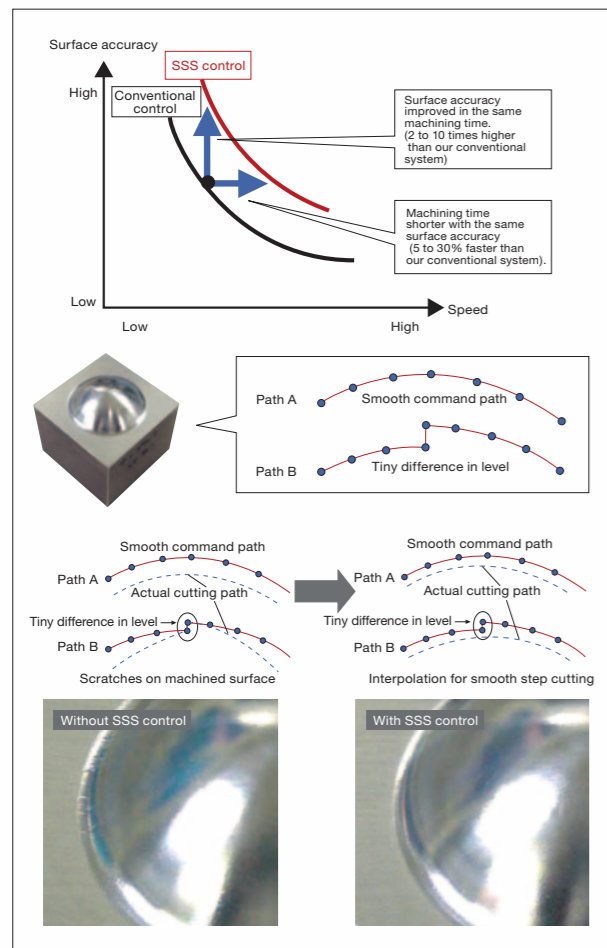

Tool Center Point Control (Machining Center System)



*M750VS, M750VW only

Control is performed at the speed of the table coordinate system so that the tool center point traces a straight line. This function contributes to high-accuracy machining on the machining surfaces.

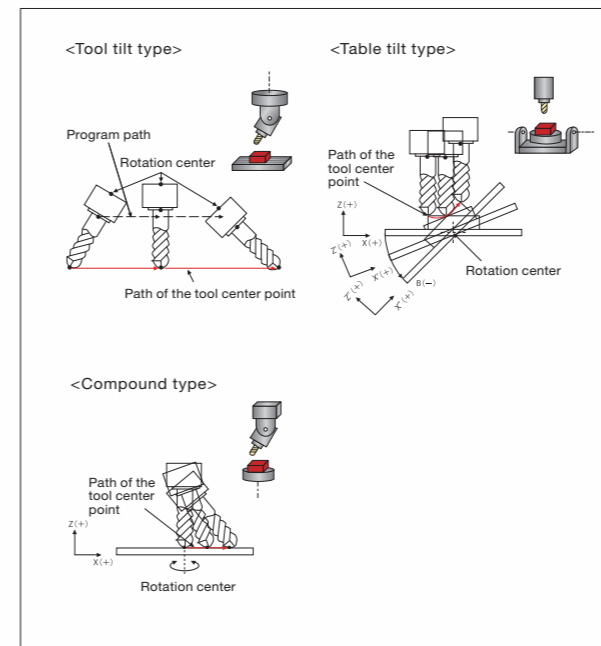

Tool Handle Feed & Interruption (Machining Center System)



*M730VS, M730VW, M750VS, M750VW only

The Tool Handle Feed & Interruption function enables you to perform handle feed by making the tool diameter direction as an X or Y axis of complicated workpiece under five-axis machining. The tool position can be changed without moving the tool tip.

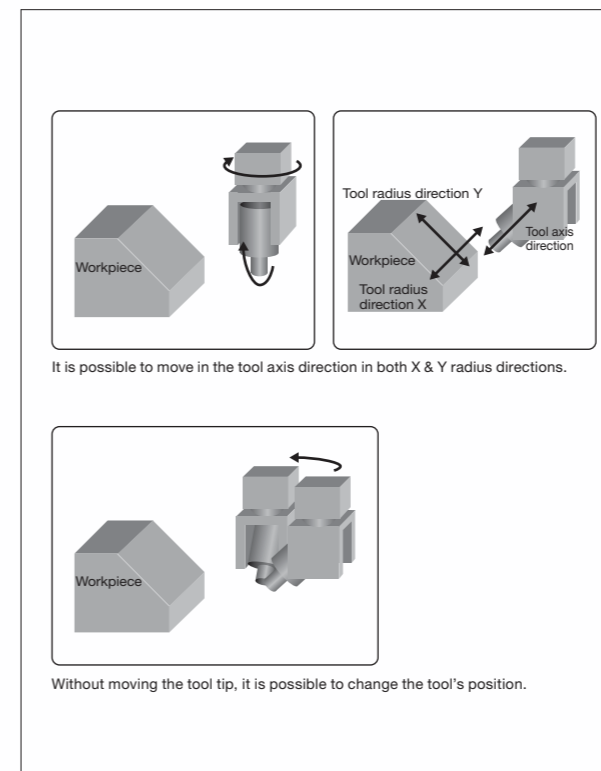

M700v series

Inclined Surface Machining (Machining Center System)



You can rotate or move the origin of the original coordinate system parallel to define a feature coordinate system. To start machining, issue normal program commands to the arbitrary plane (inclined surface) in space. The feature coordinate system is set again according to the tool axis's direction. The machining program can be created without paying attention to the direction of the coordinate system or tool axis rotational direction.

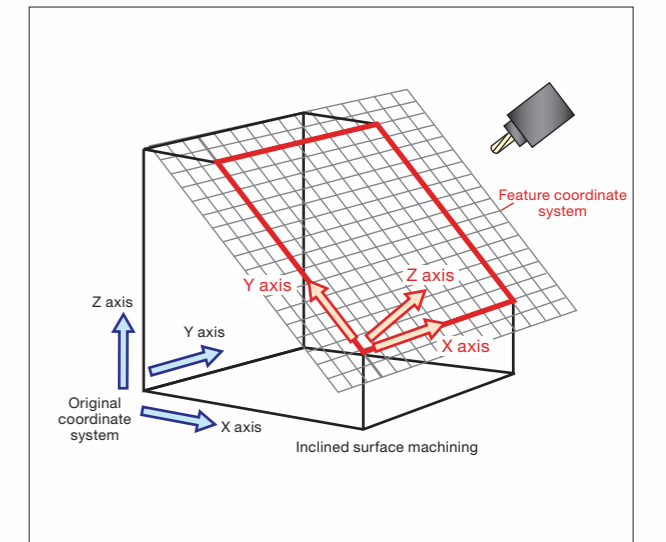

3D Machine Interference Check

*M730VW, M750VW only

- This function prevents interference on a machine model (in both manual and automatic operations) before it actually happens in the machine.
- The part to interfere can be checked by moving, rotating or enlarging the models.
- Interference can be prevented for a tilt-type tool axis and rotating table. (Useful when soft limit is not enough to prevent interference)

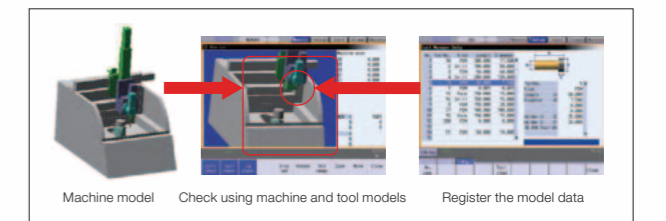

Example of detecting a tool interference while a tilt type tool is rotating

When a possibility of interference is detected on a machine model, the motor decelerates to a stop before interfering. The part to interfere is displayed in a different color.

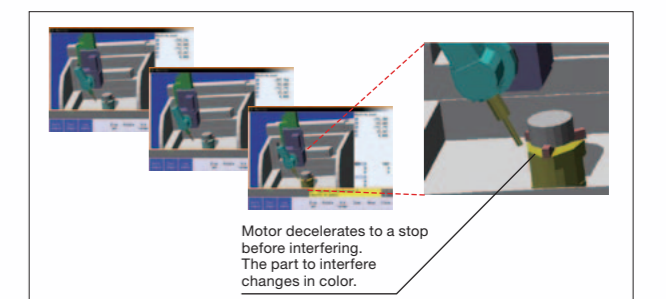

Technologies

Various Functions for Compound Machining

Supports various compound machining applications, from multi-part system program paths for multi-axis machining centers to multi-axis milling and hobbing.

Multi-part Systems Multi-axis

A maximum of two part systems and 16 axes can be controlled for the machining center. A maximum of four part systems and 16 axes can be controlled for the lathe. (A maximum of two part systems and 12 axes for M720VS, M720VW Series)

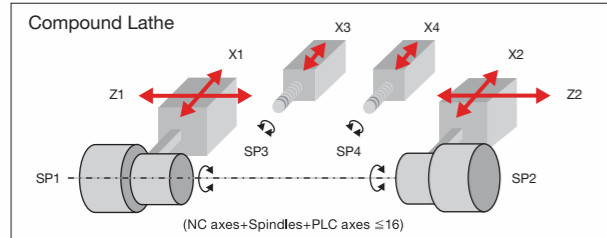
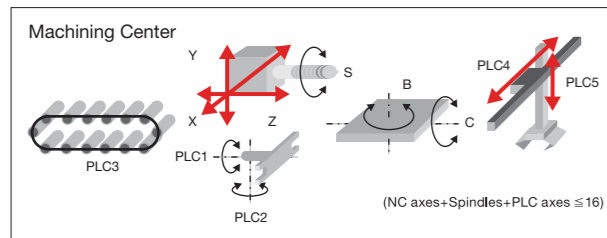

Control Axis Synchronization Across Part Systems (Lathe System)

Synchronization control enables an arbitrary control axis in the other part system to move in synchronization with the movement command assigned to an arbitrary control axis.

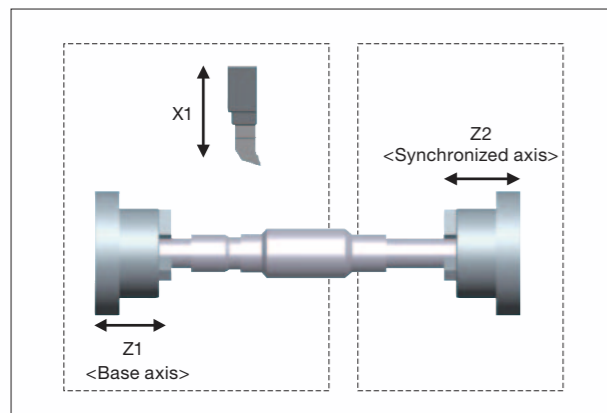

Multi-part System Program Management

Separate programs, used in each part system, can be managed under a common name in the multi-part system. This function facilitates management of the process programs that are simultaneously executed in the multi-part systems.

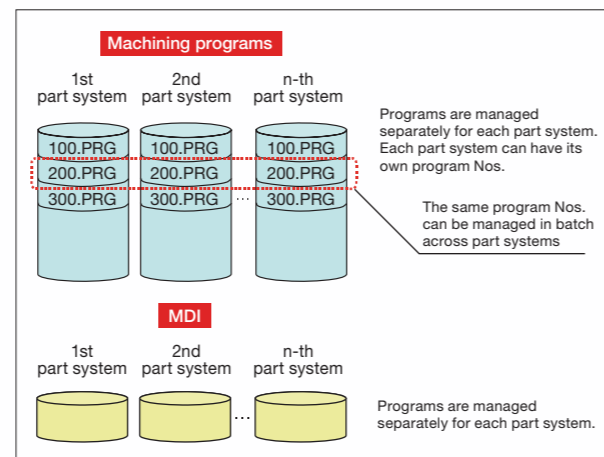

Control Axis Superimposition (Lathe System)

- This function enables machining using a certain part system simultaneously with that of another part system by superimposing their movements.
- This is effective when machining in multiple part systems is executed simultaneously. It allows for an axis to shift its coordinate system relative to the system using the axis.

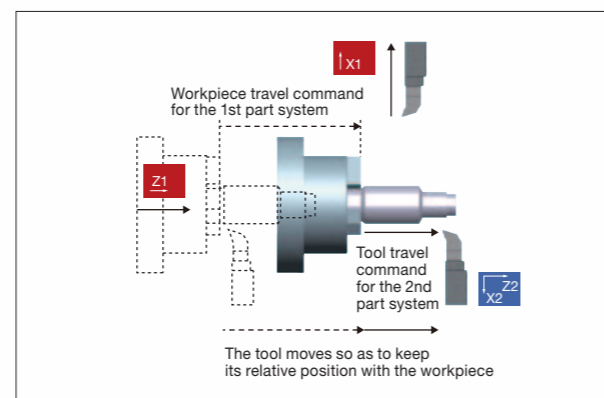

Milling Interpolation (Lathe System)

This function converts the commands programmed for the orthogonal coordinate axes into linear axis movements (tool movements) and rotary axis movements (workpiece rotation) to control the contours. This enables milling operations using a lathe without a Y axis.

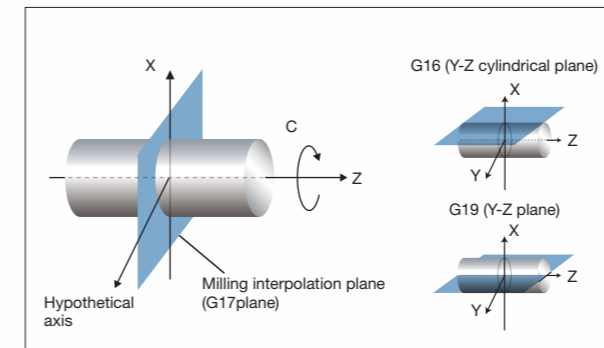

Balance Cut (Lathe System)

- Deflection can be minimized by holding tools simultaneously from both sides of the workpiece and using them in synchronization to machine the workpiece (balance cutting).
- The machining time can be reduced by machining with two tools.

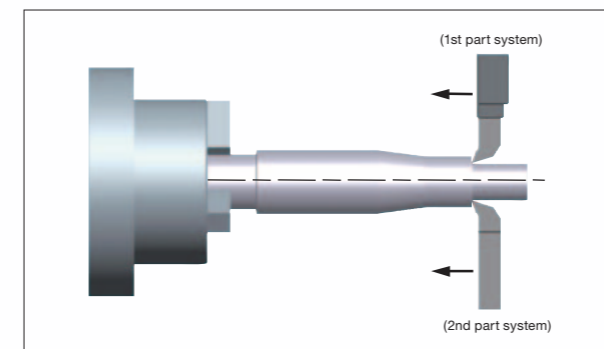

Hobbing (Lathe System)

- G code format is available for hobbing.
- A spur gear can be machined by synchronously rotating the hob axis and the workpiece axis in a constant ratio. A helical gear can be machined by compensating the workpiece axis according to the gear torsion angle for the Z axis movement.

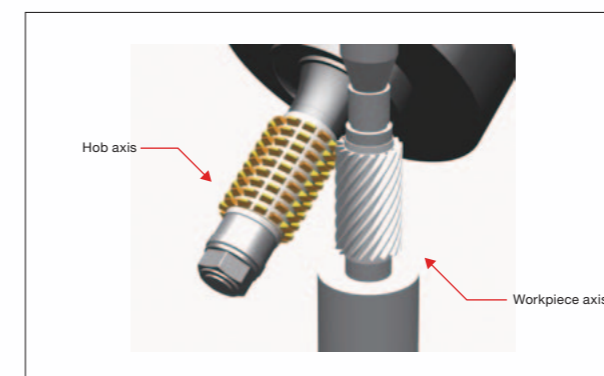

M700v series

2-part System Synchronous Thread Cutting (Lathe System)

- 2-part system synchronous thread cutting allows the 1st part system and the 2nd part system to perform thread cutting simultaneously for the same spindle.
- 2-part system synchronous thread cutting has two commands; command (G76.1) for cutting threads in two places simultaneously, which is known as "2-part system synchronous thread cutting cycle I"; and command (G76.2) for cutting a thread using the two part systems simultaneously, which is known as "2-part system synchronous thread cutting cycle II".

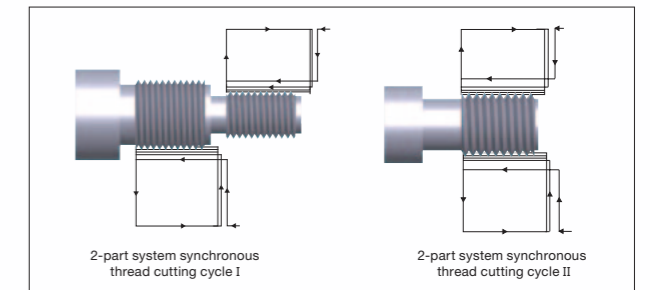

Inclined Axis Control (Lathe System)

- Even when the control axes configuring a machine are mounted at an angle other than 90 degrees, this function enables it to be programmed and controlled in the same way as with an orthogonal axis.
- The inclination angle is set using a parameter, and axes are controlled using the movement amounts of the axes which are obtained through conversion and compensation using this angle.

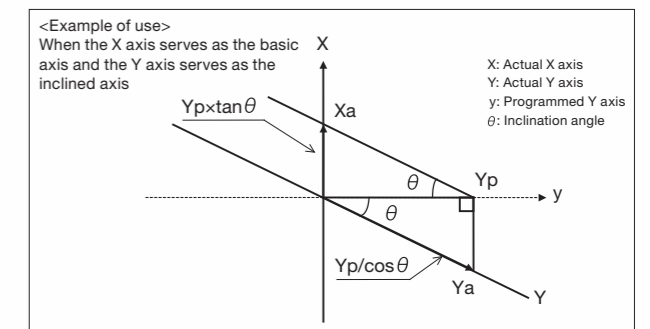

Mixed Control (cross axis control) (Lathe System)

The control axes of each part system can be exchanged using a program command. This enables the axis defined as the axis of the 1st part system to be operated as the axis of the 2nd part system.

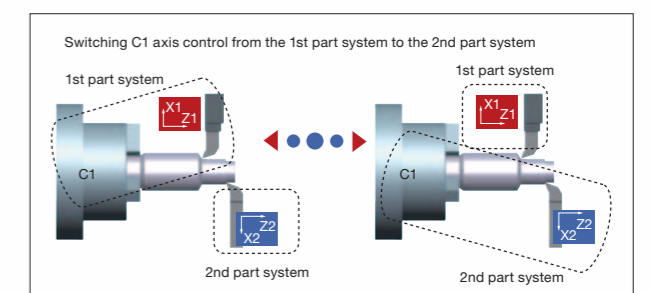

Solution

Customization/Support Tool

NC Designer and other Software Applications tools are available to support the customization of the machine. Some software applications support a C Language Library to support a higher level of customization.

NC Designer (Screen Design Tool)



- By laying out ready-made standard parts, you can easily create original screens without programming.
- When using touch panel display, a machine operation panel can be built on the NC display.
- Events of the standard parts can be described using macros.
- Using the C language source generation function of NC Designer, customized functions can be added by programming in C language. (Dedicated development environment necessary.)

- Simply by locating parts of various functions on the screen, it is possible to create custom screens easily.
- It is possible to check the performance of custom screens on a personal computer.

Develop screen configuration

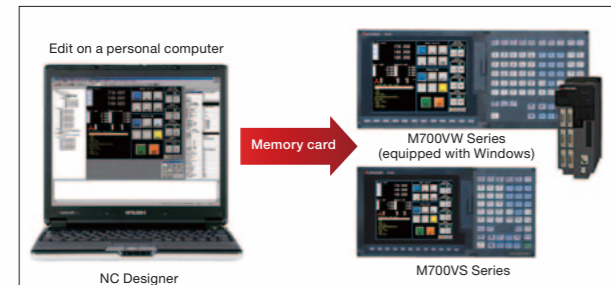
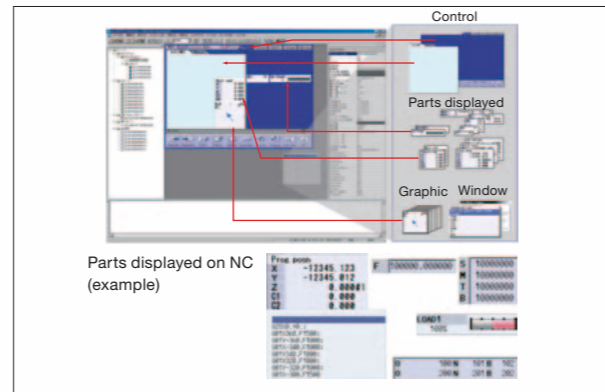

GX Developer (PLC Programming Tool)

The MELSEC programming tool, offering a wide array of functions and easy use, allows for convenient program design and debugging. Linking with a simulator or other utility allows for the efficient creation of desired programs.

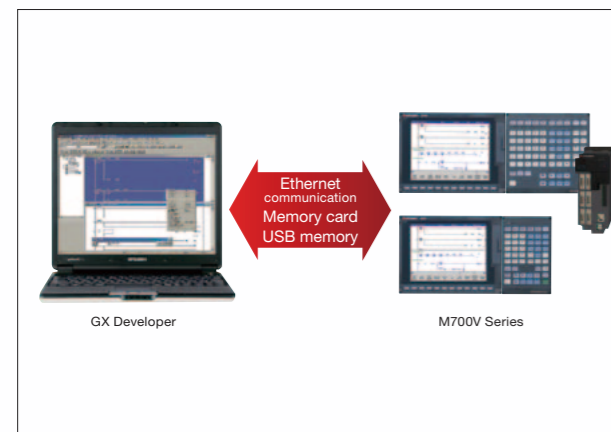

NC Trainer (MITSUBISHI CNC Training Tool)

- NC Trainer is an application for operating the screens of MITSUBISHI CNC M700V Series and machining programs. This application can be used for learning operating CNC and checking the operations of the machining programs.
- NC Trainer plus can also be used for checking the sequence program and custom screens.



Servo Selection Tool

By selecting the machine configuration model and inputting the machine specifications, the optimal servo motor meeting specifications can be selected. Other selection functions which fully support drive system selection are also available. This tool can be downloaded from MELFANSweb free of charge.

<Main functions>
Servo motor capacity selection, regenerative resistor capacity selection, spindle acceleration/deceleration time calculation, power supply capacity selection, power supply facility capacity calculation, etc.

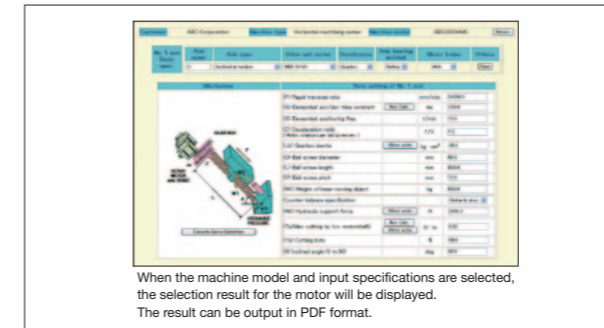

NC Configurator2 (Parameter Setup Support Tool)

The NC data file necessary for NC control and machine operation (such as parameters, tool data and common variables) can be edited on a personal computer. This tool can be downloaded from MELFANSweb free of charge. (Some functions are subject to fees.)

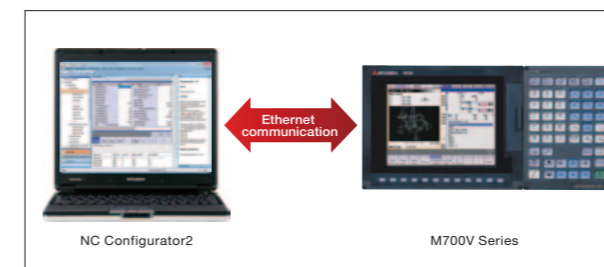

NC Explorer (Data Transfer Tool)

By connecting the NC and host personal computer via Ethernet, data such as machining programs can easily be shared. This tool can be downloaded from MELFANSweb free of charge.

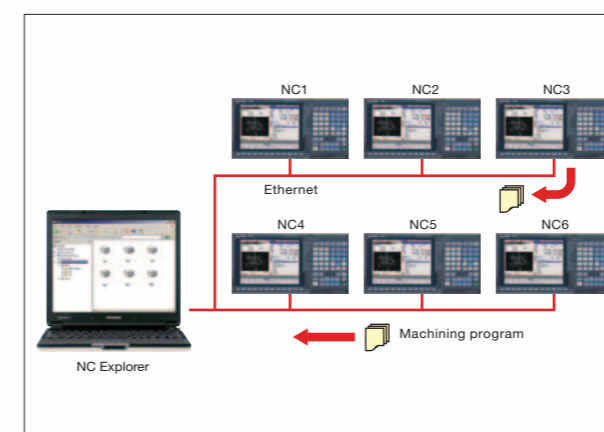

M700V series

MS Configurator (Servo Adjustment Support Tool)

Servo parameters can be automatically adjusted by activating the motor using machining programs for adjustment or vibration signals, and measuring/analyzing the machine characteristics. This tool can be downloaded from MELFANSweb free of charge.

<Main functions>
Bode diagram measurement display, speed loop gain adjustment, position loop gain adjustment, notch filter setting, acceleration/deceleration time constant adjustment, circularity adjustment and servo waveform measurement.

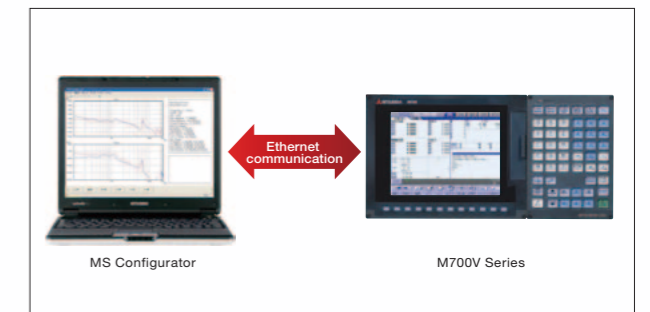

NC Monitor (Remote Monitoring Tool)

An identical NC display screen can be displayed on a personal computer. By connecting a personal computer to the NC unit when necessary, various data can be checked and set using the same HMI as the standard NC screen.

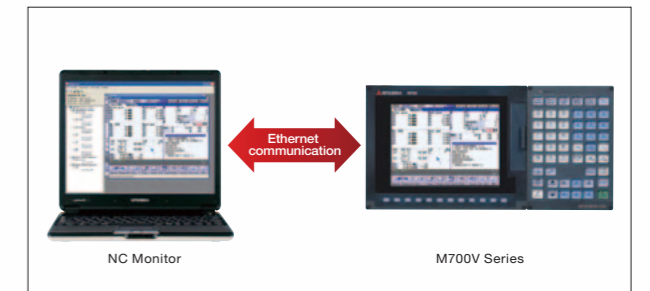

Magicpro-NAVI MILL on PC Magicpro-NAVI LATHE on PC* (Simple programming tool for use with personal computer)

Simple programming functions "NAVI MILL" and "NAVI LATHE" are available on a personal computer. The programs made by these tools can be forwarded to NC by using NC Explorer and can be executed.

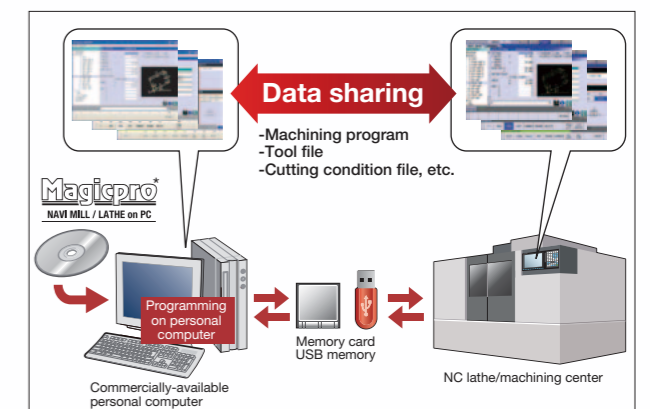

*Magicpro World is a registered trademark of Mitsubishi Electric Mechatronics Software Corporation.

Main Specifications

Specifications	Machining center system			Lathe system			Machining center system			Lathe system		
	M720VS	M730VS	M750VS	M720VS	M730VS	M750VS	M720VW	M730VW	M750VW	M720VW	M730VW	M750VW
Max. number of axes (NC axes + Spindles + PLC axes)	12	16		12	16		12	16		12	16	
Max. number of NC axes (in total for all the part systems)	8	16		12	16		8	16		12	16	
Max. number of spindles	4			4			4			4		
Max. number of PLC axes	6			6			6			6		
Max. number of auxiliary axes	—			—			4			6		
Max. number of PLC indexing axes	4	6		4	6		4	6		4	6	
Number of simultaneous contouring control axes	4	8		4	8		4	8		4	8	
Max. number of NC axes in a part system	6	8		6	8		6	8		6	8	
Max. number of part systems	2			2			2			2		
CF card in control unit	—			—			Available			Available		
Front IC card mode	Available			Available			Available			Available		
Hard disk mode	—			—			Available			Available		
Least command increment	0.1µm	1nm		0.1µm	1nm		0.1µm	1nm		0.1µm	1nm	
Least control increment	1nm			1nm			1nm			1nm		
Max. program capacity	2,000kB (5,120m)			2,000kB (5,120m)			2,000kB (5,120m)			2,000kB (5,120m)		
Max. PLC program capacity	128,000 steps			128,000 steps			128,000 steps			128,000 steps		

*Maximum specifications including optional specifications are listed.

Control Unit

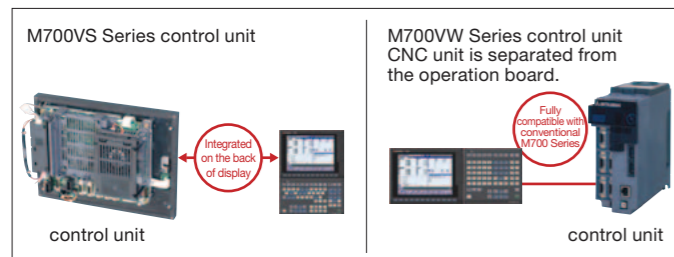

MITSUBISHI CNC Machine Operation Panel

Model	Specifications	Dimensions (mm)
FCU7-KB921	Key switch 55 points, LED 55 points MITSUBISHI standard key layout	260 (width) x 140 (height)
FCU7-KB926	Rotary switches (spindle override, cutting override) Select switch (memory protection) Emergency stop push-button	140 (width) x 140 (height)

-The internal components of the machine operation panel are protected against water and oil (IP65F).
-Refer to the product brochure for details.

Displays & Keyboards

		M700VS					
Keyboard	Display	FCU7-DU120-11 8.4-type		FCU7-DU140-11 10.4-type		FCU7-DU140-31 10.4-type touch panel	
		FCU7-KB024 sheet keys			FCU7-KB044 sheet keys		
FCU7-KB026 clear keys			FCU7-KB046 clear keys				
—	—	—	FCU7-KB048 clear keys				
FCU7-KB029 sheet keys			FCU7-KB047 clear keys				

		M700VW					
Keyboard	Display	FCU7-DA646-11 10.4-type		FCU7-DA636-11 15-type		FCU7-DA636-33 15-type touch panel	
		FCU7-KB041 clear keys					
FCU7-KB045 clear keys							

The internal components of the keyboard are protected against water and oil (IP65F). The interface for USB memory and CF card (PCMCIA II for M700VW Series) are mounted on the front panel of the display.

Drive Units

High-performance Servo/Spindle Drives MDS-D/DH Series

- With the fastest current control cycle, basic performance is drastically enhanced (high-gain control). A combination of high-speed servo motor and high-accuracy detector helps enhance overall drive performance.
- The connection between the drive unit and CNC is fast and reliable optical communication.
- A line of drive units driving a maximum of two spindles is available, contributing to a reduction in control panel size.



Multi-hybrid Drives MDS-DM Series

- The multi-hybrid drive unit drives a maximum of three servo axes and one spindle.
- The connection between the drive unit and CNC is fast and reliable optical communication.
- A power regeneration system that efficiently uses energy during deceleration as power contributes to highly-frequent acceleration/deceleration and energy savings.



Servo/Spindle Drives MDS-D-SVJ3/SPJ3 Series

- Ultra-compact drive units with built-in power supplies contribute to reducing control panel size.
- The connection between the drive unit and CNC is fast and reliable optical communication.
- A high-efficiency fin and low-loss power module have enabled unit downsizing, which also leads to a reduction in control panel size.



Servo Motors

Medium-inertia Motor HF Series

- High-inertia machine accuracy is ensured. Suitable for machines requiring quick acceleration.
- Range: 0.5 to 9 [kW]
- Maximum speed: 4,000 or 5,000 [r/min]
- Supports three types of detectors with a resolution of 260,000, 1 million or 16 million p/rev.

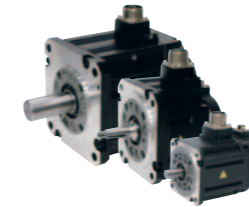

Low-inertia Motor HF-KP Series

- Suitable for an auxiliary axis that requires high-speed positioning
- Range: 0.2 to 0.75 [kW]
- Maximum speed: 6,000 [r/min]
- Supports a detector with a resolution of 260,000p/rev.

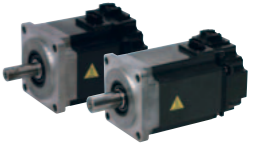

Linear Servo Motor LM-F Series

- Use in clean environments is possible since no ball screws are used and therefore contamination from grease is not an issue.
- Elimination of transmission mechanisms which include backlash, enables smooth and quiet operation even at high speeds.
- Dimensions:
Length: 290 to 1,010 [mm]
Width: 120 to 240 [mm]



Direct Drive Servo Motor TM-RB Series

- High-torque direct-drive combined motor with a high-gain control system provides quick acceleration and positioning, which makes rotation smoother.
- Suitable for a rotary axis that drives a table or spindle head.
- Range:
Maximum torque: 36 to 1,280 [N·m]



Spindle Motors

High-performance New Type Spindle Motor SJ-D Series

- Motor energy loss has been significantly reduced by optimizing the magnetic circuit.
- Product line:
Normal SJ-D Series 3.7 to 11 [kW]
Compact & light SJ-DJ Series 5.5 to 15 [kW]



High-performance Spindle Motor SJ-V Series

- A vast range of spindle motors is available, all ready to support diversified machine tool needs.
- Product line:
Normal SJ-V Series 0.75 to 55 [kW]
Wide-range constant output:
SJ-V Series 5.5 to 18.5 [kW]
High-speed: SJ-V-Z Series 2.2 to 22 [kW]
Hollow-shaft: SJ-VS Series 5.5 to 18.5 [kW]



Low-inertia, High-speed Spindle Motor SJ-VL Series

- The spindle dedicated to tapping machines requiring faster drilling and tapping.
- The low-inertia reduces acceleration/deceleration time, resulting in higher productivity.
- Product line:
Low-inertia normal SJ-VL Series 3.0 to 11 [kW]
Low-inertia hollow shaft SJ-VLS Series 3.7 to 11 [kW]



Tool Spindle Motor HF-KP/HF-SP Series

- Taking advantage of the characteristics of a servo motor such as smallness and high-output, this motor serves as a compact and high-output spindle motor which is capable of high-speed rotation (6,000r/min). This motor contributes to downsizing of spindles, such as the rotary tool spindle.
- Product line:
Small capacity HF-KP Series 0.4 to 0.9 [kW]
Medium capacity HF-SP Series 2.2 to 4 [kW]



Built-in Spindle Motor

- As feedback communication is serial, the resolution is significantly enhanced (Max. 4 million p/rev)
- The adjustment PCB has been eliminated to achieve adjustment-free conditions. The standard gap has been reduced to 0.3mm.



IPM Spindle Motor

- In answer to demands for downsizing and higher efficiency, an IPM motor has been introduced for further energy savings.
- A reduction in acceleration/deceleration time contributes to shorter cycle times.



Refer to the specifications manuals.

 **Safety Warning**

To ensure proper use of the products listed in this catalog, please be sure to read the instruction manual prior to use.

Mitsubishi Electric Corporation Nagoya Works is a factory certified for ISO14001 (standards for environmental management systems) and ISO9001 (standards for quality assurance management systems)



for a greener tomorrow

Eco Changes is the Mitsubishi Electric Group's environmental statement, and expresses the Group's stance on environmental management. Through a wide range of businesses, we are helping contribute to the realization of a sustainable society.



MITSUBISHI ELECTRIC CORPORATION

HEAD OFFICE: TOKYO BLDG., 2-7-3, MARUNOUCHI, CHIYODA-KU, TOKYO 100-8310, JAPAN
<http://Global.MitsubishiElectric.com>

BNP-A1210-D[ENG]
(ENGLISH)